

Everest G12R Series 505-530W

108-cell HJT Half-cell Solar Module



HJT-0BB Technology

Shorter current transport path, better low-light performance, and higher power generation.



Sealing with PIB

Stronger moisture resistance, greater air impermeability to extend module lifespan.



Ideal Choice for Rooftop Projects

Designed with aesthetics in mind, Ideal choice for residential and C&I rooftop projects.

Aesthetic Black

For reference only



Complete System and Product Certifications:

- IEC61215, IEC61730
- ISO9001: 2015 Quality Management System
- ISO14001: 2015 Environment Management System
- ISO45001: 2018 Occupational Health and Safety
- IEC62941: 2019 Terrestrial Photovoltaic (PV) Modules-quality System for PV Module Manufacturing
- IEC/TS62994: 2019 Photovoltaic (PV) Modules Through the Life Cycle-environmental Health and Safety (EH&S) Risk Assessment-general Principles and Nomenclature

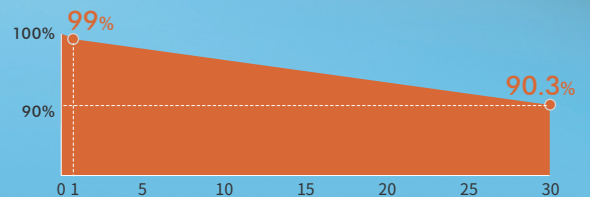

* First year power degradation < 1%
 * Annual power degradation (2-30 year) < 0.3%
 * Power output until the 30th year > 90.3%

HSN-210R-S108 505-530W

108-Half-Cell HJT Module

- BloombergNEF Tier 1 PV module manufacturer
- Reinsurance underwritten by Ariel Re

Engineering Drawings

Unit: mm

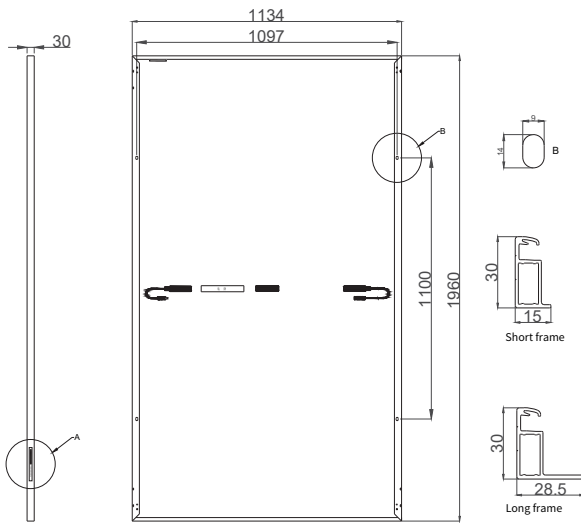

Mechanical Characteristics

Cell Type	HJT
No. of Cells	108 (6x18)
Dimensions	1960x1134x30mm
Weight	27.1 kg
Junction Box	IP68
Cable	4mm ² ; +1250mm or customized; UV resistant
Connector	MC4 / MC4-Evo2 / MC4-Evo2A / PV-H4 / Z4S-abcd / PV-ZH202B
Frame	Anodized aluminum alloy frame
Max Static Load (front side/rear side)	5400Pa / 2400Pa
Glass	Dual glass, 2.0mm

Electrical Characteristics

STC

HSN-210R-S108	DSB505	DSB510	DSB515	DSB520	DSB525	DSB530
Maximum Power (Pmax/W)	505	510	515	520	525	530
Module Efficiency (%)	22.7	22.9	23.2	23.4	23.6	23.9
Maximum Power Voltage (Vmp/V)	34.27	34.38	34.49	34.60	34.71	34.82
Maximum Power Current (Imp/A)	14.74	14.84	14.94	15.04	15.14	15.24
Open Circuit Voltage (Voc/V)	40.87	40.98	41.09	41.20	41.31	41.42
Short Circuit Current (Isc/A)	15.59	15.70	15.81	15.92	16.03	16.14

STC: AM1.5, 1000W/m², 25°C.

NOCT

Maximum Power (Pmax/W)	385	389	393	397	400	404
Maximum Power Voltage (Vmp/V)	32.73	32.83	32.93	33.03	33.13	33.23
Maximum Power Current (Imp/A)	11.78	11.86	11.94	12.02	12.10	12.18
Open Circuit Voltage (Voc/V)	39.01	39.11	39.22	39.32	39.43	39.53
Short Circuit Current (Isc/A)	12.46	12.55	12.64	12.72	12.81	12.90

NOCT: AM1.5, 800W/m², 20°C, 1m/s.

I-V Curve

(HSN-210R-S108DSB510)

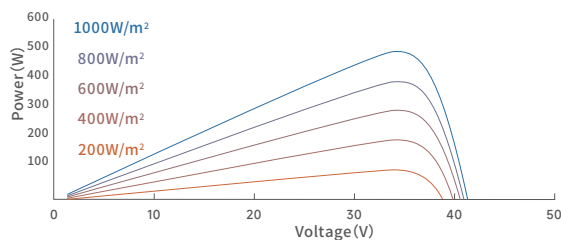
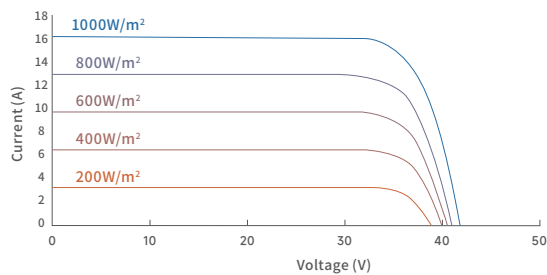

Operating Conditions

Nominal Operating Cell Temp.	44±2°C
Operating Temperature	-40~+85°C
Maximum System Voltage	DC1500V (IEC)
Maximum Series Fuse Rating	30A
Tolerance of Pmax	0~+3%
Power Selection	0~+5W
Safety Class	Class II

Temperature Coefficients

Temperature Coefficient of Pmax	-0.24%/°C
Temperature Coefficient of Voc	-0.22%/°C
Temperature Coefficient of Isc	+0.04%/°C

Packaging

	40HQ
Modules Per Pallet	36
Pallets Per Container	24
Modules Per Container	864



ANHUI HUASUN ENERGY CO., LTD. All rights reserved © 2020-2024

NO.99 Qingliu Road, Economic and Technological Development Zone, Xuancheng, Anhui, China
 Tel: 0086-563-3318095 www.huasunsolar.com
 sales@huasunsolar.com customerservice@huasunsolar.com

With the development of technology and the iterative updating of products, the technical specification of products released by HUASUN in the future may differ from those listed in this datasheet. HUASUN reserves the right to change the technical specification of the products at any time without prior notice, and the technical specification of the products ordered by the customers are subject to the technical specification agreed upon in the legally binding contract signed by both parties. The final interpretation of the datasheet is reserved by HUASUN.